

Spare Parts | Twin AP160 Ultra

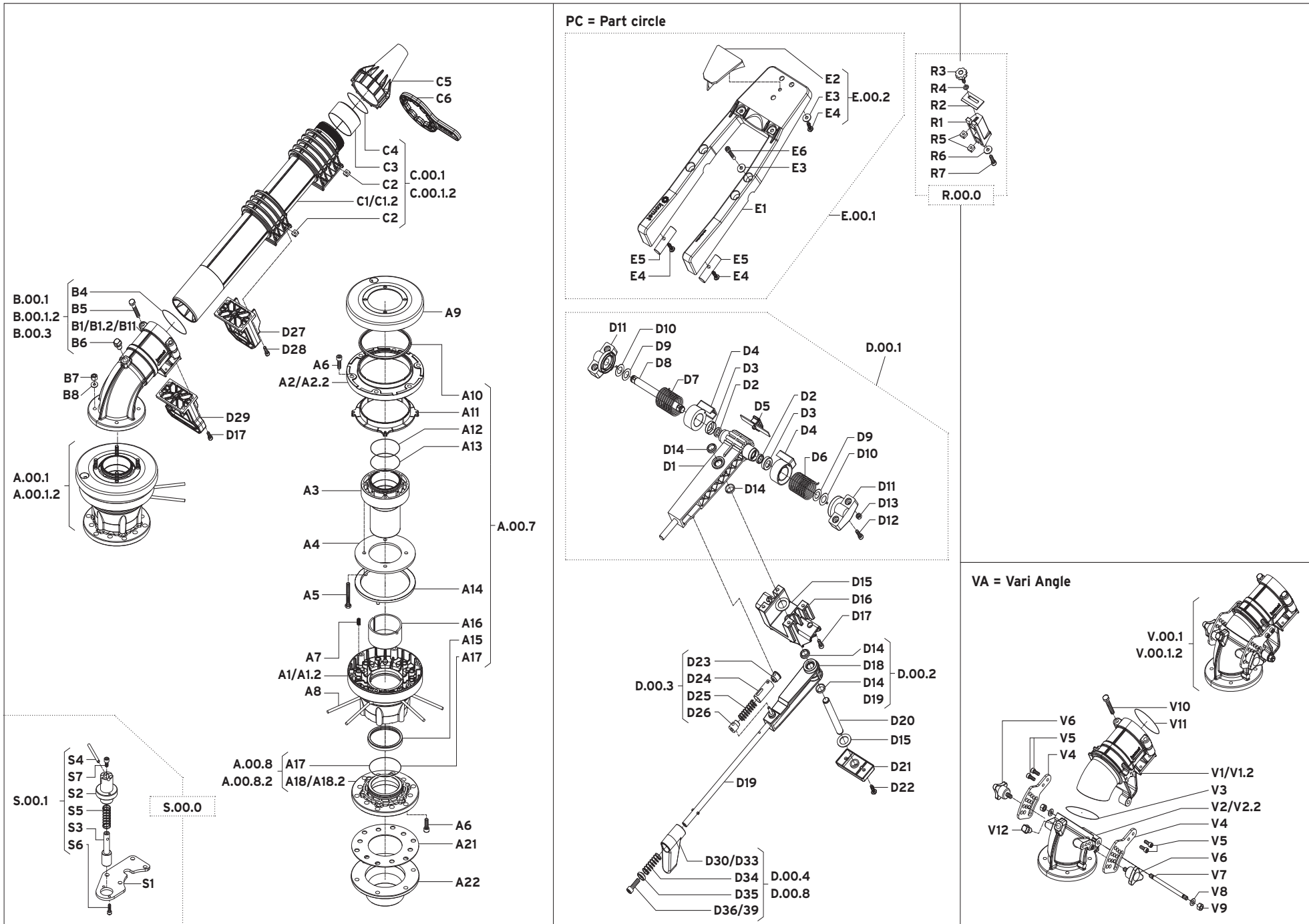

Spare Parts | Twin AP160 Ultra

	ENGLISH Description	DEUTSCH Bezeichnung	ITALIANO Denominazione	FRANCAIS Désignation	Q.ty Stk. Q.tà Q.té	Part Number Artikel-Nummer Codice Articolo Référence Pièce
A.00.1	Kit Housing/flg. PC	Kit Körper/Flansch PC	Kit Corpo/flg. PC	Kit Corps/bride PC	1	07010658
A.00.1.2	Kit Housing/flg. PC-CP	Kit Körper/Flansch PC-CP	Kit Corpo/flg. PC-CP	Kit Corps/bride PC-CP	1	07010698
A.00.7	Kit Brake	Kit Bremse	Kit Freno	Kit Frein	1	07010660
A.00.8	Kit Adapter/flange	Kit Anschluss/Flansch	Kit Attacco/flangia	Kit Raccord/bride	1	07010661
A.00.8.2	Kit Adapter/flange CP	Kit Anschluss/Flansch CP	Kit Attacco/flangia CP	Kit Raccord/bride CP	1	07010699
A.1	Housing bearing	Lagergehäuse	Corpo cuscinetto	Corps roulement	1	03010125
A.1.2	Housing bearing CP	Lagergehäuse CP	Corpo cuscinetto CP	Corps roulement CP	1	03010162
A.2	Housing cover	Deckel Lagergehäuse	Coperchio corpo	Couvercle corps	1	03010124
A.2.2	Housing cover CP	Deckel Lagergehäuse CP	Coperchio corpo CP	Couvercle corps CP	1	03010163
A.3	Brake cylinder	Bremszylinder	Canotto centrale	Cylindre central	1	07010676
A.4	Brake disk	Bremsscheibe	Disco freno	Disque frein	1	02010557
A.5	Bolt M8x60	Schraube M8x60	Vite M8x60	Vis M8x60	4	02010544
A.6	Bolt M8x25	Schraube M8x25	Vite M8x25	Vis M8x25	12	02010176
A.7	Brake spring	Bremsfeder	Molla per freno	Ressort frein	6	02010113
A.8	Trip stop ring	Sektorring	Anello settore	Anneau secteur	2	02010551
A.9	Antidust cover	Staubdeckel	Coperchio parapolvere	Couvercle antipoussiere	1	04010660
A.10	Antidust ring	Staubring	Anello parapolvere	Anneau antipoussiere	1	04010661
A.11	Brake pad	Bremssegment	Pastiglia freno	Pastille frein	4	04010662
A.12	O-Ring 72,76X1,78	O-Ring 72,76X1,78	O-Ring 72,76X1,78	O-Ring 72,76X1,78	1	02010585
A.13	O-Ring 73X3	O-Ring 73X3	O-Ring 73X3	O-Ring 73X3	1	02010552
A.14	Friction disk	Reibscheibe	Disco frizione	Disque embrayage	1	04010664
A.15	Lip seal	Lippen-Dichtung	Guarnizione a labbro	Joint a levre	1	02010549
A.16	Bearing	Lagerhülse	Cuscinetto	Roulement	1	04010665
A.17	O-Ring 79X3	O-Ring 79X3	O-Ring 79X3	O-Ring 79X3	1	02010550
A.18	Adapter/flange	Anschluss/Flansch	Attacco/flangia	Raccord/bride	1	03010119
A.18.2	Adapter/flange CP	Anschluss/Flansch CP	Attacco/flangia CP	Raccord/bride CP	1	03010164
A.21	Gasket for flange connection	Flachdichtung Flanschanschluss	Guarniz. piana attacco flg.	Joint plat pour raccord bride	1	04010800
A.22	Adapter flange/3"NPT	Anschluss Flansch/3"NPT	Attacco flangia/3"NPT	Raccord bride/3"NPT	1	02010356
B.00.1	Kit Elbow 24'	Kit Krümmer 24'	Kit Curva 24'	Kit Coude 24'	1	07010662
B.00.1.2	Kit Elbow 24' CP	Kit Krümmer 24' CP	Kit Curva 24' CP	Kit Coude 24' CP	1	07010700
B.00.3	Kit Elbow 44'	Kit Krümmer 44'	Kit Curva 44'	Kit Coude 44'	1	07010766
B.1	Elbow 24'	Krümmer 24'	Curva 24'	Coude 24'	1	03010116
B.1.2	Elbow 24' CP	Krümmer 24' CP	Curva 24' CP	Coude 24' CP	1	03010165
B.4	O-Ring 75X3	O-Ring 75X3	O-Ring 75X3	O-Ring 75X3	1	02010553
B.5	Bolt M8x50	Schraube M8x50	Vite M8x50	Vis M8x50	2	02010032
B.6	Plug	Pfropfen	Tappo	Bouchon	1	04010523
B.7	Nut M8	Mutter M8	Dado M8	Ecrou M8	4	02010038
B.8	Washer 8	Scheibe 8	Rondella 8	Rondelle 8	4	02010041
B.11	Elbow 44'	Krümmer 44'	Curva 44'	Coude 44'	1	07010764
C.00.1	Kit Barrel	Kit Strahlrohr	Kit Tubo di lancio	Kit Fut	1	07010663
C.00.1.2	Kit Barrel CP	Kit Strahlrohr CP	Kit Tubo di lancio CP	Kit Fut CP	1	07010701
C.1	Barrel	Strahlrohr	Tubo di lancio	Fut	1	04010653
C.1.2	Barrel CP	Strahlrohr CP	Tubo di lancio CP	Fut CP	1	04010765
C.2	Square nut M6	Mutter vierkant M6	Dado quadro M6	Ecrou carre M6	8	02010240
C.3	Inset barrel	Einsatz Strahlrohr	Inserto tubo di lancio	Insert fut	1	04010753
C.4	O-Ring 167	O-Ring 167	O-Ring 167	O-Ring 167	1	02010175
C.5-18	Taper bore nozzle 18 mm / 0.71"	Weitwurfdüse 18 mm / 0.71"	Ugello conico 18 mm / 0.71"	Buse Ing portee 18 mm / 0.71"	1	04010702
C.5-19	Taper bore nozzle 19 mm / 0.75"	Weitwurfdüse 19 mm / 0.75"	Ugello conico 19 mm / 0.75"	Buse Ing portee 19 mm / 0.75"	1	04010703
C.5-20	Taper bore nozzle 20 mm / 0.79"	Weitwurfdüse 20 mm / 0.79"	Ugello conico 20 mm / 0.79"	Buse Ing portee 20 mm / 0.79"	1	04010704
C.5-21	Taper bore nozzle 21 mm / 0.83"	Weitwurfdüse 21 mm / 0.83"	Ugello conico 21 mm / 0.83"	Buse Ing portee 21 mm / 0.83"	1	04010705
C.5-22	Taper bore nozzle 22 mm / 0.87"	Weitwurfdüse 22 mm / 0.87"	Ugello conico 22 mm / 0.87"	Buse Ing portee 22 mm / 0.87"	1	04010706
C.5-23	Taper bore nozzle 23 mm / 0.91"	Weitwurfdüse 23 mm / 0.91"	Ugello conico 23 mm / 0.91"	Buse Ing portee 23 mm / 0.91"	1	04010707
C.5-24	Taper bore nozzle 24 mm / 0.94"	Weitwurfdüse 24 mm / 0.94"	Ugello conico 24 mm / 0.94"	Buse Ing portee 24 mm / 0.94"	1	04010708
C.5-25	Taper bore nozzle 25 mm / 0.98"	Weitwurfdüse 25 mm / 0.98"	Ugello conico 25 mm / 0.98"	Buse Ing portee 25 mm / 0.98"	1	04010709
C.5-26	Taper bore nozzle 26 mm / 1.02"	Weitwurfdüse 26 mm / 1.02"	Ugello conico 26 mm / 1.02"	Buse Ing portee 26 mm / 1.02"	1	04010710
C.5-27	Taper bore nozzle 27 mm / 1.06"	Weitwurfdüse 27 mm / 1.06"	Ugello conico 27 mm / 1.06"	Buse Ing portee 27 mm / 1.06"	1	04010711
C.5-28	Taper bore nozzle 28 mm / 1.10"	Weitwurfdüse 28 mm / 1.10"	Ugello conico 28 mm / 1.10"	Buse Ing portee 28 mm / 1.10"	1	04010712
C.5-29	Taper bore nozzle 29 mm / 1.14"	Weitwurfdüse 29 mm / 1.14"	Ugello conico 29 mm / 1.14"	Buse Ing portee 29 mm / 1.14"	1	04010713

Spare Parts | Twin AP160 Ultra

	ENGLISH Description	DEUTSCH Bezeichnung	ITALIANO Denominazione	FRANCAIS Désignation	Q.ty Stk. Q.tà Q.té	Part Number Artikel-Nummer Codice Articolo Référence Pièce
C.5-30	Taper bore nozzle 30 mm / 1.18"	Weitwurfdüse 30 mm / 1.18"	Ugello conico 30 mm / 1.18"	Buse lng portee 30 mm / 1.18"	1	04010714
C.5-31	Taper bore nozzle 31 mm / 1.22"	Weitwurfdüse 31 mm / 1.22"	Ugello conico 31 mm / 1.22"	Buse lng portee 31 mm / 1.22"	1	04010715
C.5-32	Taper bore nozzle 32 mm / 1.26"	Weitwurfdüse 32 mm / 1.26"	Ugello conico 32 mm / 1.26"	Buse lng portee 32 mm / 1.26"	1	04010716
C.5-33	Taper bore nozzle 33 mm / 1.30"	Weitwurfdüse 33 mm / 1.30"	Ugello conico 33 mm / 1.30"	Buse lng portee 33 mm / 1.30"	1	04010717
C.5-34	Taper bore nozzle 34 mm / 1.34"	Weitwurfdüse 34 mm / 1.34"	Ugello conico 34 mm / 1.34"	Buse lng portee 34 mm / 1.34"	1	04010718
C.5-35	Taper bore nozzle 35 mm / 1.38"	Weitwurfdüse 35 mm / 1.38"	Ugello conico 35 mm / 1.38"	Buse lng portee 35 mm / 1.38"	1	04010719
C.5-36	Taper bore nozzle 36 mm / 1.42"	Weitwurfdüse 36 mm / 1.42"	Ugello conico 36 mm / 1.42"	Buse lng portee 36 mm / 1.42"	1	04010720
C.5-37	Taper bore nozzle 37 mm / 1.46"	Weitwurfdüse 37 mm / 1.46"	Ugello conico 37 mm / 1.46"	Buse lng portee 37 mm / 1.46"	1	04010721
C.5-38	Taper bore nozzle 38 mm / 1.50"	Weitwurfdüse 38 mm / 1.50"	Ugello conico 38 mm / 1.50"	Buse lng portee 38 mm / 1.50"	1	04010722
C.6	Nozzle wrench	Düsenschlüssel	Chiave ugello	Cle pour buse	1	04010742
D.00.1	Kit Trip lever upper PC	Kit Kreuzgelenk PC	Kit Leva crociera PC	Kit Levier declenchement PC	1	07010665
D.1	Shift lever upper	Kreuzgelenk oben	Leva crociera superiore	Levier declenchement sup.	1	04010500
D.2	Labyrinth seal	Labyrinth-Dichtung	Guarnizione labirinto	Joint labyrinthe	2	04010204
D.3	Cover for hub	Deckel für Nabe	Coprizzo	Couvercle pour moyeu	2	02010121
D.4	Spring housing internal	Federgehäuse innen	Scatola molla interna	Boite ressort interne	2	04010328
D.5	Speed shift lever	Selektierhebel Geschwindigkeit	Leva selettore velocità	Levier selecteur vitesse	1	04010329
D.6	Spring drive arm right	Feder Schwingarm Rechts	Molla braccio oscillante destro	R ressort bras oscillant droite	1	02010538
D.7	Spring drive arm left	Feder Schwingarm Links	Molla braccio oscillante sinistro	R ressort bras oscillant gauche	1	02010539
D.8	Shaft drive arm	Welle Schwingarm	Perno braccio oscillante	Pivot bras oscillant	1	04010656
D.9	Washer 0.5	Scheibe 0.5	Rondella 0.5	Rondelle 0.5	2	02010645
D.10	Washer W/Pin 0.5	Scheibe mit Stopper 0.5	Rondella antigiro 0.5	Rondelle avec cran d'arret 0.5	2	02010276
D.11	Bracket drive arm	Schelle für Schwingarm	Cavallotto braccio osc.	Etrier bras oscillant	2	04010657
D.12	Bolt M6x20	Schraube M6x20	Vite M6x20	Vis M6x20	2	02010130
D.13	Nut M6	Mutter M6	Dado M6	Ecrou M6	4	02010128
D.14	Dust seal	Abstreif-Dichtung	Guarnizione raschiatore	Joint antipoussiere	4	02010119
D.15	Washer	Scheibe	Rondella	Rondelle	2	04010333
D.16	Housing for PC	Gehäuse für PC	Corpo per PC	Corps pour PC	1	04010636
D.17	Bolt M6x16	Schraube M6x16	Vite M6x16	Vis M6x16	8	02010169
D.00.2	Kit Shift lever lower	Kit Schaltgelenk unten	Kit Leva crociera inferiore	Kit Levier declenchement inf.	1	07010666
D.18	Shift lever lower	Schaltgelenk unten	Leva crociera inferiore	Levier declenchement inf.	1	04010673
D.19	Pin for trip lever	Stift für Schalthebel	Spina leva scatto settore	Chevillon pour levier inversion	1	02010574
D.20	Shaft for housings	Welle für Gehäuse	Perno per corpo	Pivot pour corps	1	04010634
D.21	Cover trip levers housing	Deckel Sektorgehäuse	Coperchio corpo settore	Couvercle corps inversion	1	04010635
D.22	Screw Ej-K60x20	Schraube Ej-K60x20	Vite Ej-K60x20	Vis Ej-K60x20	2	02010166
D.00.3	Kit Trip spring	Kit Sektorfeder	Kit Molla scatto settore	Kit Ressort inversion	1	07010657
D.23	Plug sleeve	Kappe für Hülse	Tappo bussola	Bouchon douille	1	04010211
D.24	Spring sleeve	Federhülse	Bussola scatto settore	Douille ressort	1	02010142
D.25	Trip spring	Feder für Schaltung	Molla scatto settore	R ressort inversion	1	02010347
D.26	Guide for sleeve	Gleitnuppe für Hülse	Nottolino per bussola	Taquet pour douille	1	04010210
D.27	Stop for shift lever upper	Anschlag Kreuzgelenk	Arresto corciera settore	Butee levier declenchement sup.	1	04010644
D.28	Bolt M6x20	Schraube M6x20	Vite M6x20	Vis M6x20	4	02010130
D.29	Stopper for rod	Anschlag Sektorwelle	Arresto asta settore	Butee tige secteur	1	04010650
D.00.4	Kit Trip lever 24'	Kit Schalthebel 24'	Kit Leva settore 24'	Kit Levier inversion 24'	1	07010647
D.00.8	Kit Trip lever VA	Kit Schalthebel VA	Kit Leva settore VA	Kit Levier inversion VA	1	07010677
D.30	Trip lever 24'	Schalthebel 24'	Leva scatto settore 24'	Levier declenchement inv. 24'	1	04010645
D.33	Trip lever VA	Schalthebel VA	Leva scatto settore VA	Levier declenchement inv. VA	1	04010733
D.34	Spring for trip shift lever	Feder Schalthebel	Molla leva scatto settore	R ressort p. levier inversion	1	02010249
D.35	Washer	Scheibe	Rondella	Rondelle	1	04010751
D.36	Bolt M8x25	Schraube M8x25	Vite M8x25	Vis M8x25	1	02010176
D.39	Bolt M8x25 Flat Head	Schraube M8x25 Flachkopf	Vite M8x25 Testa Bassa	Vis M8x25 Tête Basse	1	02010678
E.00.1	Kit Drive arm	Kit Schwingarm	Kit Braccio oscillante	Kit Bras oscillant	1	07010668
E.00.2	Kit Deflector	Kit Deflektor	Kit Deflettore	Kit Deflecteur	1	07010669
E.1	Drive arm	Schwinghebel	Braccio oscillante	Bras oscillant	1	04010655
E.2	Deflector 47	Deflektor 47	Deflettore 47	Deflecteur 47	1	04010737
E.3	Washer 6.5	Scheibe 6.5	Rondella 6.5	Rondelle 6.5	7	02010160
E.4	Screw Ej-K60x20	Schraube Ej-K60x20	Vite Ej-K60x20	Vis Ej-K60x20	5	02010166
E.5	Counterweight drive arm	Gegengewicht Schwingarm	Contrappeso braccio osc.	Contrepoids bras oscillant	2	04010628
E.6	Bolt M6x35	Schraube M6x35	Vite M6x35	Vis M6x35	4	02010138

Spare Parts | Twin AP160 Ultra

	ENGLISH Description	DEUTSCH Bezeichnung	ITALIANO Denominazione	FRANCAIS Désignation	Q.ty Stk. Q.tà	Part Number Artikel-Nummer Codice Articolo Référence Pièce
R.00.0	Kit Dyn. Jet-breaker	Kit Dyn. Strahlstörer	Kit Spartiacqua	Kit Brise-Jet Dynamique	1	07010674
R.1	Base Dyn. Jet-breaker	Sockel Dyn. Störer	Base spartiacqua	Base brise-Jet Dyn.	1	04010338
R.2	Blade Jet-breaker	Schneide Strahlstörer	Lama spartiacqua	Lame brise-Jet	1	02010606
R.3	Bolt W/Grip	Sterngriff-Schraube	Vite con pomello	Vis avec bouton étoile	1	02010432
R.4	Washer 6	Scheibe 6	Rondella 6	Rondelle 6	1	02010042
R.5	Square nut M6	Mutter vierkant M6	Dado quadro M6	Ecrou carre M6	2	02010240
R.6	Washer 6.5	Scheibe 6.5	Rondella 6.5	Rondelle 6.5	1	02010160
R.7	Bolt M6x20	Schraube M6x20	Vite M6x20	Vis M6x20	1	02010130
V.00.1	Kit Vari Angle	Kit Vari Angle	Kit Vari Angle	Kit Vari Angle	1	07010670
V.00.1.2	Kit Vari Angle CP	Kit Vari Angle CP	Kit Vari Angle CP	Kit Vari Angle CP	1	07010703
V1	Upper elbow	Halbkrümmer oben	Semicurva superiore	Coude superieur	1	03010152
V1.2	Upper elbow CP	Halbkrümmer oben CP	Semicurva superiore CP	Coude superieur CP	1	03010166
V2	Lower elbow	Halbkrümmer unten	Semicurva inferiore	Coude inferieur	1	07010678
V2.2	Lower elbow CP	Halbkrümmer unten CP	Semicurva inferiore CP	Coude inferieur CP	1	07010704
V3	O-Ring 80x5	O-Ring 80x5	O-Ring 80x5	O-Ring 80x5	1	02010584
V4	Selector plate for trajectory	Fixierlasche für Strahlwinkel	Piastra selettore angolo	Languette du selecteur angle	2	02010567
V5	Bolt M6x16	Schraube M6x16	Vite M6x16	Vis M6x16	4	02010169
V6	Bolt W/Grip	Sterngriff-Schraube	Vite con pomello	Vis avec bouton étoile	2	02010573
V7	Shaft	Gewindewelle	Tirante	Tirant	1	04010755
V8	Washer 8	Scheibe 8	Rondella 8	Rondelle 8	2	02010041
V9	Nut M8	Mutter M8	Dado M8	Ecrou M8	2	02010038
V10	Bolt M8x50	Schraube M8x50	Vite M8x50	Vis M8x50	2	02010032
V11	O-Ring 75X3	O-Ring 75X3	O-Ring 75X3	O-Ring 75X3	1	02010553
V12	Plug	Pfropfen	Tappo	Bouchon	1	04010523
S.00.0	Kit Lock for transport	Kit Transportsicherung	Kit Arresto per trasporto	Kit Fixation pour transport	1	07010672
S.00.1	Kit Lock	Kit Arretierung	Kit Arresto	Kit Fixation	1	07010654
S.1	Support lock/counterweight	Halter Sicherung/Gegengewicht	Supporto arresto/contrappeso	Support fixation/contrepoids	1	02010589
S.2	Housing lock	Gehäuse Arretierung	Corpo arresto	Corps fixation	1	04010758
S.3	Shaft	Zapfen	Perno	Pivot	1	04010759
S.4	Pin	Stift	Spina	Cheville	1	04010760
S.5	Spring trip shift lever/lock	Feder Schalthebel/Arretierung	Molla leva scatto settore/arresto	Ressort levier inversion/fixation	1	02010249
S.6	Bolt M5x16	Schraube M5x16	Vite M5x16	Vis M5x16	2	02010587
S.7	Bolt M6x12	Schraube M6x12	Vite M6x12	Vis M6x12	1	02010159

Grey shaded part numbers: not available as single parts, please select appropriate kit/assembly • Grau hinterlegte Ersatzteile: einzeln nicht erhältlich, sondern nur im entsprechenden Ersatzteil-Kit • Pezzi di ricambio su fondo grigio: non fornibili singolarmente, selezionare il kit ricambio desiderato • Pièces de rechange sur fond gris: ne sont pas disponibles séparément, sélectionner le kit pièces souhaite • Las referencias sombreadas en gris: no están disponibles como piezas solas, por favor seleccione el equipo/conjunto apropiado • Peças com números sombreados de cinza: não disponíveis como peças individuais, por favor, selecione o conjunto/montagem apropriado.