

Spare Parts | Twin 202 Pro

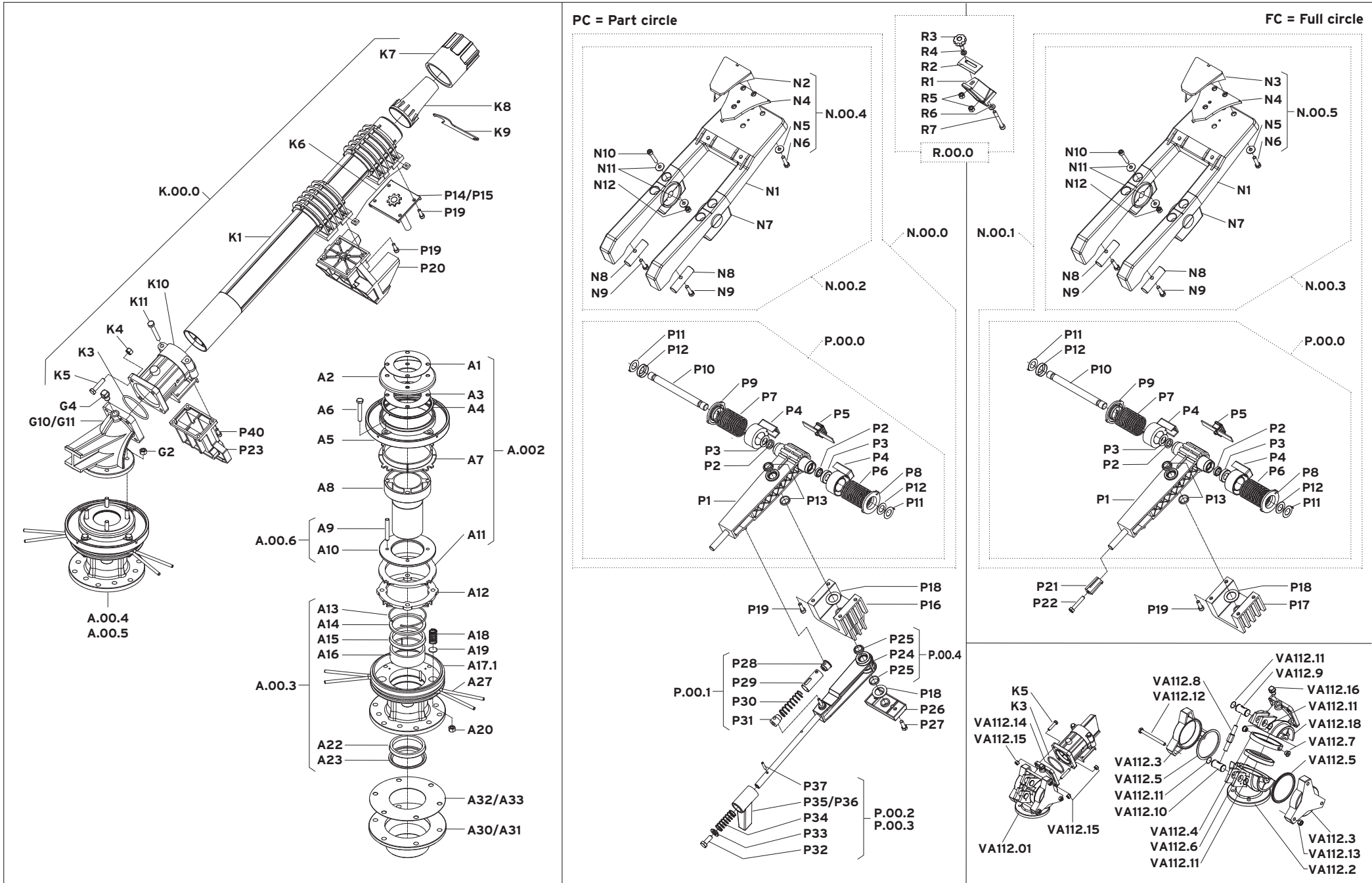

	ENGLISH	DEUTSCH	ITALIANO	FRANCAIS	Q.ty Stk. Q.tà Q.té	Part Number Artikel-Nummer Codice Articolo Référence Pièce	
	Description	Bezeichnung	Denominazione	Désignation		New Neue Nuovo Nouvelle	Old Alte Vecchio Vieille
A.00-4	Kit Housing Pro PC	Kit Körper Pro PC	Kit Corpo Pro PC	Kit Corps Pro PC	1	07010533	TW202-0-A00.4
A.00-5	Kit Housing Pro FC	Kit Körper Pro FC	Kit Corpo Pro FC	Kit Corps Pro FC	1	07010534	TW202-0-A00.5
A.00-2	Kit Brake	Kit Bremse	Kit Freno	Kit Frein	1	07010310	TW202-0-A00.2
A.00-3	Kit Seals for bearing	Kit Dichtungen für Bremslager	Kit Guarnizioni per cuscinetto	Kit Joints pour roulement	1	07010311	TW202-0-A00.3
A.00-6	Kit Brake flange	Kit Bremsflansch	Kit Flangia freno	Kit Bride frein	1	07010535	TW202-0-A00.6
A.1	Gasket flange/elbow	Flachdichtung Flansch/Kurve	Guarniz. piana flg./curva	Joint bride/coude	1	02010099	TW202-0-A1
A.2	Antidust cover	Staubdeckel	Coperchio parapolvere	Couvercle antipoussière	1	04010081	TW202-0-A2
A.3	Gasket flange/elbow	Flachdichtung Flansch/Kurve	Guarniz. piana flg./curva	Joint bride/coude	1	02010099	TW202-0-A3
A.4	Antidust ring	Staubring	Anello parapolvere	Anneau antipoussière	1	04010082	TW202-0-A4
A.5	Brake cap	Bremsdeckel	Coperchio freno	Couvercle frein	1	03010033	TW202-0-A5
A.6	Bolt M8x50	Schraube M8x50	Vite M8x50	Vis M8x50	4	02010032	TW202-0-A6
A.7	Brake lining	Brems Scheibe	Pastiglia freno	Pastille frein	1	04010079	---
A.8	Braking cylinder	Bremszylinder	Canotto centrale	Cylindre central	1	03010079	TW202-0-A8
A.9	Bolt for brake flange	Gewindebolzen für Bremsflansch	Prigioniero flangia	Tirant pour bride frein	4	04010076	TW202-0-A9
A.10	Brake flange	Bremsflansch	Flangia freno	Bride frein	1	04010578	TW202-0-A10
A.11	Friction disk	Reibscheibe	Disco frizione	Disque embrayage	1	04010078	---
A.12	Friction pressure plate	Druckscheibe	Disco reggispinta	Disque de pression	1	04010077	TW202-0-A12
A.13	Snap ring	Federring	Anello arresto	Anneau d'arrêt	1	02010097	---
A.14	Retaining ring	Distanzring	Anello ritegno	Anneau de distance	1	04010084	---
A.15	Lip seal	Lippen-Dichtung	Guarnizione a labbro	Joint à levre	1	02010045	---
A.16	Bearing	Lagerhülse	Cuscinetto	Roulement	1	04010080	---
A.17-1	Housing bearing Pro	Lagergehäuse Pro	Corpo cuscinetto Pro	Corps roulement Pro	1	03010068	TW202-0-A17.1
A.18	Brake spring	Bremsfeder	Molla frizione	Ressort frein	4	02010098	TW202-0-A18
A.19	Pad for spring	Distanzscheibe für Feder	Pastiglia molla	Pastille pour ressort	4	02010101	TW202-0-A19
A.20	Nut M8	Mutter M8	Dado M8	Ecrou M8	4	02010038	TW202-0-A20
A.22	Lip Seal	Lippen-Dichtung	Guarnizione a labbro	Joint à levre	1	02010045	---
A.23	Antisand ring	Abstreifring	Anello parasabbia	Anneau antisable	1	04010083	---
A.27	Trip stop ring	Sektorring	Anello settore	Anneau secteur	2	02010198	TW202-0-A27
A.30	Adapter flange/3"NPT	Anschluss Flansch/3"NPT	Attacco flangia/3"NPT	Raccord bride/3"NPT	1	02010356	TW202-0-A30
A.31	Adapter flange/3"BSP	Anschluss Flansch/3"BSP	Attacco flangia/3"BSP	Raccord bride/3"BSP	1	---	TW202-0-A31
A.32	Gasket for flange connection	Flachdichtung Flanschanschluss	Guarniz. piana attacco flg.	Joint plat pour raccord bride	1	02010100	TW202-0-A32
A.33	Gasket flange connec. rubber	Flachdichtung Flansch Gummi	Guarniz. piana a. flg. gomma	Joint plat racc. bride caoutc	1	02010355	TW202-0-A33
G.10	Elbow 24'	Krümmer 24'	Curva 24'	Coude 24'	1	03010047	TW202-0-G10
G.2	Nut M8	Mutter M8	Dado M8	Ecrou M8	4	02010038	TW202-0-G2
G.4	Plug	Pfropfen	Tappo	Bouchon	1	04010523	TW202-0-G4
G.11	Elbow 44'	Krümmer 44'	Curva 44'	Coude 44'	1	03010074	TW202-0-G11
K.00.0	Kit Barrel	Kit Strahlrohr	Kit Tubo di lancio	Kit Fût	1	07010236	TW202-X-K00.0
K.1	Barrel	Strahlrohr	Tubo di lancio	Fût	1	04010492	---
K.3	O-Ring 167	O-Ring 167	O-Ring 167	O-Ring 167	1	02010175	TW202-0-K3
K.4	Nut M8	Mutter M8	Dado M8	Ecrou M8	4	02010038	TW202-0-K4
K.5	Bolt M8x35	Schraube M8x35	Vite M8x35	Vis M8x35	4	02010191	TW202-0-K5
K.6	Square nut M6	Mutter Vierkant M6	Dado quadro M6	Ecrou carre M6	8	02010240	TW202-0-K6
K.7	Nozzle holder	Überwurfmutter	Bocchettone	Ecrou buse	1	04010086	TW202-X-K7
K.8.20	T. bore nozzle 20 mm / 0.79"	Weitwurfdüse 20 mm / 0.79"	Ugello conico 20 mm / 0.79"	Buse lng portée 20 mm / 0.79"	1	04010394	TW202-0-K8-20
K.8.22	T. bore nozzle 22 mm / 0.87"	Weitwurfdüse 22 mm / 0.87"	Ugello conico 22 mm / 0.87"	Buse lng portée 22 mm / 0.87"	1	04010609	TW202-0-K8-22
K.8.22.5	T. bore nozzle 22,5 mm / 0.89"	Weitwurfdüse 22,5 mm / 0.89"	Ugello conico 22,5 mm / 0.89"	Buse lng portée 22,5 mm / 0.89"	1	04010395	TW202-0-K8-22.5
K.8.23	T. bore nozzle 23 mm / 0.91"	Weitwurfdüse 23 mm / 0.91"	Ugello conico 23 mm / 0.91"	Buse lng portée 23 mm / 0.91"	1	04010610	TW202-0-K8-23
K.8.24	T. bore nozzle 24 mm / 0.94"	Weitwurfdüse 24 mm / 0.94"	Ugello conico 24 mm / 0.94"	Buse lng portée 24 mm / 0.94"	1	04010611	TW202-0-K8-24
K.8.25	T. Bore Nozzle 25 mm / 0.98"	Weitwurfdüse 25 mm / 0.98"	Ugello conico 25 mm / 0.98"	Buse lng portée 25 mm / 0.98"	1	04010396	TW202-0-K8-25
K.8.26	T. Bore Nozzle 26 mm / 1.02"	Weitwurfdüse 26 mm / 1.02"	Ugello conico 26 mm / 1.02"	Buse lng portée 26 mm / 1.02"	1	04010613	TW202-0-K8-26
K.8.27	T. Bore Nozzle 27 mm / 1.06"	Weitwurfdüse 27 mm / 1.06"	Ugello conico 27 mm / 1.06"	Buse lng portée 27 mm / 1.06"	1	04010614	TW202-0-K8-27
K.8.27.5	T. bore nozzle 27,5 mm / 1.08"	Weitwurfdüse 27,5 mm / 1.08"	Ugello conico 27,5 mm / 1.08"	Buse lng portée 27,5 mm / 1.08"	1	04010397	TW202-0-K8-27.5
K.8.28	T. bore nozzle 28 mm / 1.10"	Weitwurfdüse 28 mm / 1.10"	Ugello conico 28 mm / 1.10"	Buse lng portée 28 mm / 1.10"	1	04010615	TW202-0-K8-28
K.8.30	T. bore nozzle 30 mm / 1.18"	Weitwurfdüse 30 mm / 1.18"	Ugello conico 30 mm / 1.18"	Buse lng portée 30 mm / 1.18"	1	04010398	TW202-0-K8-30
K.8.32.5	T. bore nozzle 32,5 mm / 1.28"	Weitwurfdüse 32,5 mm / 1.28"	Ugello conico 32,5 mm / 1.28"	Buse lng portée 32,5 mm / 1.28"	1	04010399	TW202-0-K8-32.5

Spare Parts | Twin 202 Pro

	ENGLISH Description	DEUTSCH Bezeichnung	ITALIANO Denominazione	FRANCAIS Désignation	Q.ty Stk. Q.tà Q.té	Part Number Artikel-Nummer Codice Articolo Référence Pièce	
						New Neue Nuovo Nouvelle	Old Aite Vecchio Vieille
K.8.35	T. bore nozzle 35 mm / 1.38"	Weitwurfdüse 35 mm / 1.38"	Ugello conico 35 mm / 1.38"	Buse lng portée 35 mm / 1.38"	1	04010400	TW202-0-K8-35
K.8.37.5	T. bore nozzle 37,5 mm / 1.48"	Weitwurfdüse 37,5 mm / 1.48"	Ugello conico 37,5 mm / 1.48"	Buse lng portée 37,5 mm / 1.48"	1	04010401	TW202-0-K8-37.5
K.8.40	T. bore nozzle 40 mm / 1.58"	Weitwurfdüse 40 mm / 1.58"	Ugello conico 40 mm / 1.58"	Buse lng portée 40 mm / 1.58"	1	04010402	TW202-0-K8-40
K.9	Nozzle wrench	Düsen Schlüssel	Chiave bocchettone	Clé de service	1	02010102	TW202-0-K9
K.10	Flange	Flansch	Flangia	Bride	1	03010056	TW202-0-K10
K.11	Bolt M8x55	Schraube M8x55	Vite M8x55	Vis M8x55	2	02010165	TW202-0-K11
N.00.0	Kit Drive arm/lever PC	Kit Schwingarm/Hebel PC	Kit Braccio osc./leva PC	Kit Bras oscillant/levier PC	1	07010238	TW202-0-N00.0
N.00.1	Kit Drive arm/lever FC	Kit Schwingarm/Hebel FC	Kit Braccio osc./leva FC	Kit Bras oscillant/levier FC	1	07010239	TW202-0-N00.1
N.00.2	Kit Drive arm PC	Kit Schwingarm PC	Kit Braccio oscillante PC	Kit Bras oscillant PC	1	07010240	TW202-0-N00.2
N.00.3	Kit Drive arm FC	Kit Schwingarm FC	Kit Braccio oscillante FC	Kit Bras oscillant FC	1	07010241	TW202-0-N00.3
N.1	Drive arm	Schwingarm	Braccio oscillante	Bras oscillant	1	04010324	---
N.00.4	Kit Deflector PC	Kit Deflektor PC	Kit Deflettore PC	Kit Déflecteur PC	1	07010242	TW202-0-N00.4
N.00.5	Kit Deflector FC	Kit Deflektor FC	Kit Deflettore FC	Kit Déflecteur FC	1	07010243	TW202-0-N00.5
N.2	Deflector 47	Deflektor 47	Deflettore 47	Déflecteur 47	1	04010415	---
N.3	Deflector 47	Deflektor 47	Deflettore 47	Déflecteur 47	1	04010415	---
N.4	Plate for deflector	Platte für Deflektor	Piastra per deflettore	Plaque pour déflecteur	1	04010243	---
N.5	Washer 6,5	Scheibe 6,5	Rondella 6,5	Rondelle 6,5	3	02010160	---
N.6	Screw EJ-K60x25	Schraube EJ-K60x25	Vite EJ-K60x25	Vis EJ-K60x25	3	02010167	---
N.7	Bracket drive arm	Schelle für Schwingarm	Cavallotto braccio osc.	Étrier bras oscillant	2	04010326	TW202-0-N7
N.8	Counterweight drive arm	Gegengewicht Schwingarm	Contrappeso braccio osc.	Contrepoids bras oscillant	2	04010325	TW202-0-N8
N.9	Screw EJ-K60x25	Schraube EJ-K60x25	Vite EJ-K60x25	Vis EJ-K60x25	2	02010167	TW202-0-N9
N.10	Bolt M6x35	Schraube M6x35	Vite M6x35	Vis M6x35	4	02010138	TW202-0-N10
N.11	Washer 6,5	Scheibe 6,5	Rondella 6,5	Rondelle 6,5	8	02010160	TW202-0-N11
N.12	Nut M6	Mutter M6	Dado M6	Ecrou M6	4	02010128	TW202-0-N12
P.00.0	Kit Trip lever upper	Kit Kreuzgelenk	Kit Leva crociera	Kit Levier déclenchement	1	07010244	TW202-0-P00.0
P.1	Shift lever upper	Kreuzgelenk oben	Leva crociera superiore	Levier déclenchement sup.	1	04010500	---
P.2	Labyrinth seal	Labyrinth-Dichtung	Guarnizione labirinto	Joint labyrinthe	2	04010204	---
P.3	Cover for hub	Deckel für Nabe	Coprismozzo	Couvercle pour moyeu	2	02010121	---
P.4	Spring housing internal	Federgehäuse innen	Scatola molla interna	Boîte ressort interne	2	04010328	TW202-0-P4
P.5	Speed shift lever	Selektierhebel Geschwindigkeit	Leva selettore velocità	Levier sélecteur vitesse	1	04010329	TW202-0-P5
P.6	Spring drive arm right	Feder Schwingarm rechts	Molla braccio osc. destro	Ressort bras osc. droit	1	02010246	TW202-0-P6
P.7	Spring drive arm left	Feder Schwingarm links	Molla braccio osc. sinistro	Ressort bras osc. gauche	1	02010247	TW202-0-P7
P.8	Spring housing external right	Federgehäuse aussen rechts	Corpo molla esterno destro	Boîte ressort externe droite	1	04010330	TW202-0-P8
P.9	Spring housing external left	Federgehäuse aussen links	Corpo molla esterno sinistro	Boîte ressort externe gauche	1	04010331	TW202-0-P9
P.10	Shaft drive arm	Welle Schwingarm	Perno braccio oscillante	Pivot bras oscillant	1	04010327	TW202-0-P10
P.11	Washer W/Pin	Scheibe mit Stopper	Rondella antigiro	Rondelle avec cran d'arrêt	2	02010276	TW202-0-P11
P.12	Washer	Scheibe	Rondella	Rondelle	2	02010149	TW202-0-P12
P.13	Dust seal	Abstreif-Dichtung	Guarnizione raschiatore	Joint antipoussière	2	02010119	TW202-0-P13
P.14	Base with shaft PC	Platte mit Welle PC	Base con perno PC	Base avec pivot PC	1	04010501	TW202-0-P14
P.15	Base with shaft FC	Platte mit Welle FC	Base con perno FC	Base avec pivot FC	1	04010504	TW202-0-P15
P.16	Housing for PC	Gehäuse für PC	Corpo per PC	Corps pour PC	1	04010502	TW202-0-P16
P.17	Housing for FC	Gehäuse für FC	Corpo per FC	Corps pour FC	1	04010505	TW202-0-P17
P.18	Washer	Scheibe	Rondella	Rondelle	2	04010333	TW202-0-P18
P.19	Bolt M6x20	Schraube M6x20	Vite M6x20	Vis M6x20	8	02010130	TW202-0-P19
P.20	Drive arm support	Schwingarm Auflage	Arresto braccio	Arrêt bras oscillant	1	04010334	TW202-0-P20
P.21	Wedge FC	Keil FC	Cuneo FC	Cône FC	1	04010340	TW202-0-P21
P.22	Screw EJ-K60x35	Schraube EJ-K60x35	Vite EJ-K60x35	Vis EJ-K60x35	1	02010184	TW202-0-P22
P.23	Stopper for rod	Anschlag Sektorwelle	Arresto asta settore	Butée tige secteur	1	04010514	TW202-X-P23
P.24	Shift lever lower	Schaltgelenk unten	Leva crociera inferiore	Levier déclenchement inf.	1	04010512	TW202-X-P24
P.25	Dust seal	Abstreif-Dichtung	Guarnizione raschiatore	Joint antipoussière	2	02010119	TW202-0-P25
P.26	Cover trip levers housing	Deckel Sektorgehäuse	Coperchio corpo settore	Couvercle corps inversion	1	04010503	TW202-0-P26
P.27	Screw EJ-K60x20	Schraube EJ-K60x20	Vite EJ-K60x20	Vis EJ-K60x20	2	02010166	TW202-0-P27
P.00.1	Kit Trip spring	Kit Sektorfeder	Kit Molla scatto settore	Kit Ressort inversion	1	07010245	TW202-0-P00.1
P.28	Plug sleeve	Kappe für Hülse	Tappo bussola	Bouchon douille	1	04010211	---
P.29	Spring sleeve	Federhülse	Bussola scatto settore	Douille ressort	1	02010142	---
P.30	Trip spring	Feder für Schaltung	Molla scatto settore	Ressort inversion	1	02010347	---
P.31	Guide for sleeve	Gleitnuppe für Hülse	Nottolino per bussola	Taquet pour douille	1	04010210	---

	ENGLISH	DEUTSCH	ITALIANO	FRANCAIS	Q.ty Stk. Q.tà Q.té	Part Number Artikel-Nummer Codice Articolo Référence Pièce	
	Description	Bezeichnung	Denominazione	Désignation		New Neue Nuovo Nouvelle	Old Alte Vecchio Vieille
P.00.2	Kit Trip lever 24'	Kit Schalthebel 24'	Kit Leva settore 24'	Kit Levier inversion 24'	1	07010246	TW202-0-P00.2
P.00.3	Kit Trip lever VA	Kit Schalthebel VA	Kit Leva settore VA	Kit Levier inversion VA	1	07010247	TW202-0-P00.3
P.32	Bolt M8x20	Schraube M8x20	Vite M8x20	Vis M8x20	1	02010036	---
P.33	Washer	Scheibe	Rondella	Rondelle	1	04010518	---
P.34	Spring for trip shift lever	Feder Schalthebel	Molla leva scatto settore	Ressort p. levier inversion	1	02010249	---
P.35	Trip lever 24'	Schalthebel 24'	Leva scatto settore 24'	Levier déclenchement inv. 24'	1	04010517	---
P.36	Trip lever VA	Schalthebel VA	Leva scatto settore VA	Levier déclenchement inv. VA	1	04010516	---
P.37	Pin for trip lever	Stift für Schalthebel	Spina per leva scatto settore	Cheville pour levier inversion	1	04010337	---
P.40	Bolt M6x16	Schraube M6x16	Vite M6x16	Vis M6x16	4	02010169	TW202-0-P40
P.00.4	Kit Shift lever lower	Kit Schaltgelenk unten	Kit Leva crociera inferiore	Kit Levier déclenchement inf.	1	07010588	TW202-X-P00.4
R.00.0	Kit Dyn. jet-breaker Pro	Kit Dyn. Strahlstörer Pro	Kit Spartiacqua Pro	Kit Brise-jet dynamique Pro	1	07010248	TW202-0-R00.0
R.1	Base dyn. jet-breaker Pro	Sockel dyn. Störer Pro	Base spartiacqua Pro	Base brise-jet dyn. Pro	1	---	---
R.2	Blade jet-breaker	Schneide Strahlstörer	Lama spartiacqua	Lame brise-jet	1	02010427	TW202-0-R2
R.3	Bolt	Schraube	Vite	Vis	1	---	---
R.4	Washer	Scheibe	Rondella	Rondelle	1	---	---
R.5	Square nut	Vierkantmutter	Dado quadro	Ecrou carré	2	---	---
R.6	Washer	Scheibe	Rondella	Rondelle	1	---	---
R.7	Bolt	Schraube	Vite	Vis	1	---	---
VA112.01	Kit Vari Angle Pro VA112	Kit Vari Angle Pro VA112	Kit Vari Angle Pro VA112	Kit Vari Angle Pro VA112	1	07010268	TW202-VA112.01
VA112.18	Upper elbow Pro VA112	Halbkrümmer oben Pro VA112	Semicurva superiore Pro VA112	Coude supérieur Pro VA112	1	03010057	TW202-VA112.18
VA112.2	Lower elbow VA112	Halbkrümmer unten VA112	Semicurva inferiore VA112	Coude inférieur VA112	1	03010023	TW202-VA112.2
VA112.3	Cover VA112	Deckel VA112	Coperchio VA112	Couvercle VA112	2	03010025	TW202-VA112.3
VA112.4	Centering ring VA112	Zentrierring VA112	Anello centraggio VA112	Anneau centrage VA112	1	04010087	TW202-VA112.4
VA112.5	Spacer	Distanzring	Anello scorrimento	Entretoise	2	04010088	TW202-VA112.5
VA112.6	Lip seal	Lippen-Dichtung	Guarnizione a labbro	Joint à levre	1	02010103	TW202-VA112.6
VA112.7	Centering bushing VA112	Zentrierbüchse VA112	Boccola centraggio VA112	Douille de centrage VA112	2	04010092	TW202-VA112.7
VA112.8	Adjusting bolt VA112	Einstellschraube VA112	Vite regolazione VA112	Vis réglage VA112	1	04010089	TW202-VA112.8
VA112.9	Bolt right threaded VA112	Bolzen mit Gew. rechts VA112	Noce filettata destra VA112	Vis filetage droit VA112	1	04010091	TW202-VA112.9
VA112.10	Bolt left threaded VA112	Bolzen mit Gew. links VA112	Noce filettata sinistra VA112	Vis filetage gauche VA112	1	04010090	TW202-VA112.10
VA112.11	Lock spring	Federring	Anello arresto	Anneau d'arrêt	4	02010104	TW202-VA112.11
VA112.12	Bolt M8x140-Drc	Schraube M8x140-Drc	Vite M8x140-Drc	Vis M8x140-Drc	3	02010147	TW202-VA112.12
VA112.13	Nut M8-AB	Mutter M8-AB	Dado M8-AB	Ecrou M8-AB	3	02010039	TW202-VA112.13
VA112.14	Bolt M8x45	Gewindebolzen M8x45	Tirante M8x45	Tirant M8x45	4	04010494	TW202-VA112.14
VA112.15	Nut M8	Mutter M8	Dado M8	Ecrou M8	6	02010038	TW202-VA112.15
VA112.16	Plug	Pfropfen	Tappo	Bouchon	1	04010523	TW202-VA112.16

Grey shaded part numbers: not available as single parts, please select appropriate kit/assembly • Grau hinterlegte Ersatzteile: einzeln nicht erhältlich, sondern nur im entsprechenden Ersatzteil-Kit • Pezzi di ricambio su fondo grigio: non fornibili singolarmente, selezionare il kit ricambio desiderato • Pièces de rechange sur fond gris: ne sont pas disponibles séparément, sélectionner le kit pièces souhaite • Las referencias sombreadas en gris: no están disponibles como piezas solas, por favor seleccione el equipo/conjunto apropiado apropiado • Peças com números sombreados de cinza: não disponíveis como peças individuais, por favor, selecione o conjunto/montagem apropriado.